

## ***Amorphus globosus* in a White Galloway Cattle**

Zafer USTA <sup>1</sup>  Björn JACOBSEN <sup>2</sup> Maren GOTTSCHALK <sup>1</sup> Ottmar DISTL <sup>1</sup>

<sup>1</sup> Institute for Animal Breeding and Genetics, University of Veterinary Medicine Hannover, DE-30559 Hannover - GERMANY

<sup>2</sup> Institute of Pathology, University of Veterinary Medicine Hannover, DE-30559 Hannover - GERMANY

Article Code: KVFD-2016-15200 Received: 02.02.2016 Accepted: 14.03.2016 Published Online: 14.03.2016

### **Abstract**

In this article, a case of an *amorphus globosus* is presented. A three years old White Galloway dam gave birth in her second pregnancy a normal calf and a malformed amorphous co-twin. The malformed co-twin was slightly flattened with an ovoid covered by white hairy skin form of 21.0x10.0x6.0 cm in size and a weight of 1600 g. The present case had an umbilical cord like structure of 20 cm in length and 2-3 cm in diameter. A small opening, resembling an oral structure, contain a tongue-like structure with lips and three milk teeth. Histological examination showed a solid mass of connective tissue, skeletal muscles, lymph, arterial vessel and glandular units and focal by cartilage tissue. The radiography clearly showed lower-upper jaw, small bone similar to a tail-like-structure and a cartilage tissue. The inbreeding coefficient of the case was 6.25% due to a common ancestor on the maternal and paternal side. This is the first report on *amorphus globosus* in White Galloway cattle including pathological, histopathological, radiological findings and pedigree analysis.

**Keywords:** *Amorphus globosus*, Galloway, Twin, Cattle

## **Beyaz Galloway Sığırdada *Amorphus globosus* Olgusu**

### **Özet**

Bu makale de bir *Amorphus Globosus* olgusu sunulmuştur. Üç yaşlı beyaz Galloway ineğin ikiz olarak şekillenen ikinci gebeliğinde bir normal buzağı ve bir de onun amorfik kusurlu ikiz partnerini doğurmuştur. Kusurlu ikiz partner, şekli hafif basık ve oval ,derisi beyaz tüylerle kaplı, 21.0x10.0x6.0 cm boyutlarında ve 1600 gr ağırlığına sahibdi. Sunulan olgu, 20 cm uzunluğunda ve 2-3 cm genişliğinde göbek bağına benzer bir oluşuma sahipti. Ağız şeklinde küçük bir açıklık ve bu açıklıkta 3 adet diş ve dudaklarla birlikte küçük dil benzeri yapı görüldü. Histolojik incelemede ise olgunun sağlam bir bağ dokusu, iskelet kasları, lenf ve arteriyel damarlar, salgı bezleri ve kıkırdak dokuya benzeyen odaklardan meydana geldiği gözlemlendi. Radyolojik incelememizde net olarak alt ve üst çenenin, kuyruğa ait olduğu düşünülen küçük kemiksi yapıların ve kıkırdak dokunun varlığı tespit edildi. İnek ve boğanın ebeveynlerinin ortak olması nedeniyle olgunun akrabalı yetiştirme katsayısı %6.25 idi. Bu olgu galloway ırkı sığırdada görülen ilk *amorphus globosus* vakası olup patolojik, histopatolojik, radyolojik bulgular ve pedigrini analizini içerir.

**Anahtar sözcükler:** *Amorphus Globosus*, Galloway, ikizlik, Sığır

### **INTRODUCTION**

*Amorphus globosus* (AG) is an imperfectly formed free twin fetus lacking a heart and invariably lacking other body parts as well. The incidences of twin births are 3.9% <sup>[1]</sup> and 4.2% <sup>[2]</sup> in dairy herds. Hossein-Zadeh et al.<sup>[1]</sup> reported calf stillbirths with 18.8% of twin calving events resulting in one or both calves as stillborn, compared with 4.0% for singleton births.

Several cases on this AG have been reported a rate of 0.4% in cattle, 0.003% humans and very rarely other domestic animals <sup>[3-13]</sup>. We present the first case of AG in Galloway cattle.

### **CASE HISTORY**

#### **Case Description**

A case of *amorphus* was notified in a farm located in Bavaria, Germany, on April 16, 2009. A normal female calf and its malformed co-twin were delivered after full term gestation from a White Galloway cattle dam. The female normal calf had normal body size and weight. The amorphous co-twin was completely covered with white hair and white skin. The present case was sired by a natural service bull kept in this herd. The dam of the case was a 3-years-old White Galloway cow with a previous normal parturition.



**İletişim (Correspondence)**



+49 176 93447448



zaferustavet@gmail.com

### Necropsy Findings

The malformed co-twin was slightly flattened with an ovoid form, a dimension of 21.0x10.0x6.0 cm and a weight of 1600 g. The present case had an umbilical cord like structure of 20 cm in length and 2-3 cm in diameter (Fig. 1A). The body of the present case had a small opening, resembling an oral structure, in which a tongue-like structure with deformed lips and three milk teeth were present (Fig. 1B). In addition, the case had a tail formation on the opposite side to oral-like-structure. We observed ventral and dorsal median notches in the upper and lower jaw. The cross section of the body showed abundant connective tissue, glandular units, blood vessels and cartilage tissue (Fig. 1C). The oral cavity ended blindly.

### Histopathological Findings

Tissue sample from the oral-like-structure showed cutaneous mucosal cells indicative for tongue tissue. Body tissue samples contained connective tissue, skeletal muscles, lymph tissue, arterial vessels, cartilage tissue as well as tubular and glandular structures.

### Radiological Findings

The radiography of the present case showed a lower and upper jaw (Fig. 2), a small bone similar to a tail-like-structure and cartilage.

### Pedigree Analysis

The autosite twin of the dam showed no congenital abnormalities. The inbreeding coefficient for the case was 6.25% due to a common ancestor on the maternal and paternal side (Fig. 3).

## DISCUSSION

The present case of an amorphus globosus (AG) co-twin is the first reported in White Galloway cattle. The main criteria for an AG including no specific shape of a body but covered by skin and hairs, were confirmed for this case. In addition, a small tongue with an oral cavity and a rudimentary bone formation were observed. Other forms of acardiac twins could be clearly excluded. The acardius anceps shows a partly developed head and a deformed

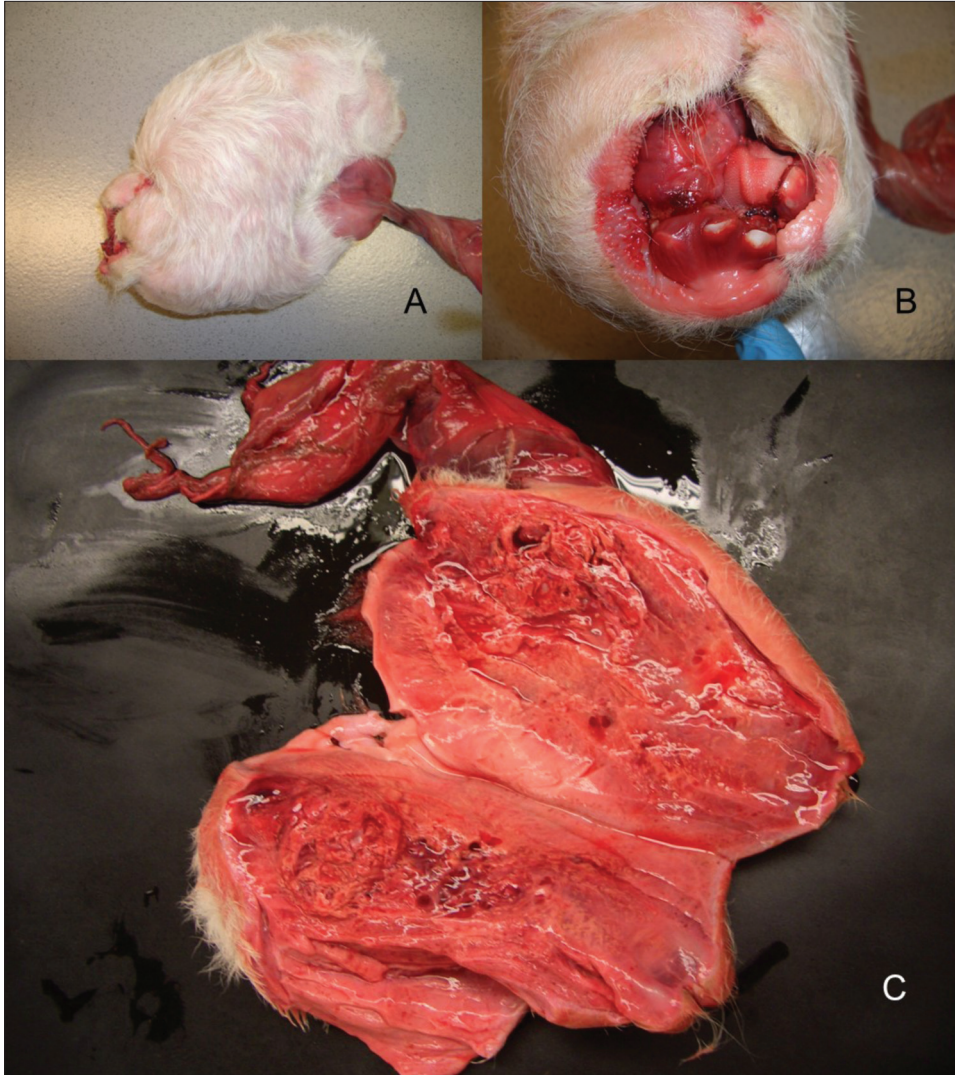

**Fig 1.** Present case of amorphus globosus (AG). A: Appearance of AG, B: Mouth of present case with teeth, lip and tongue, C: The cross section of the case showed abundant connective tissue, glandular units, blood vessels and the focal detection of cartilage tissue

**Şekil 1.** Sunulan olgu. A: Amorphus globosus dış görünüm, B: Diş, dudak ve dil ile birlikte sunulan olgunun ağız, C: Olgunun enine kesitinde görülen bol miktarda bağ dokusu, lenf bezi üniteleri, kan damarları ve kırkırdak dokusundan oluşmuş odak tespiti

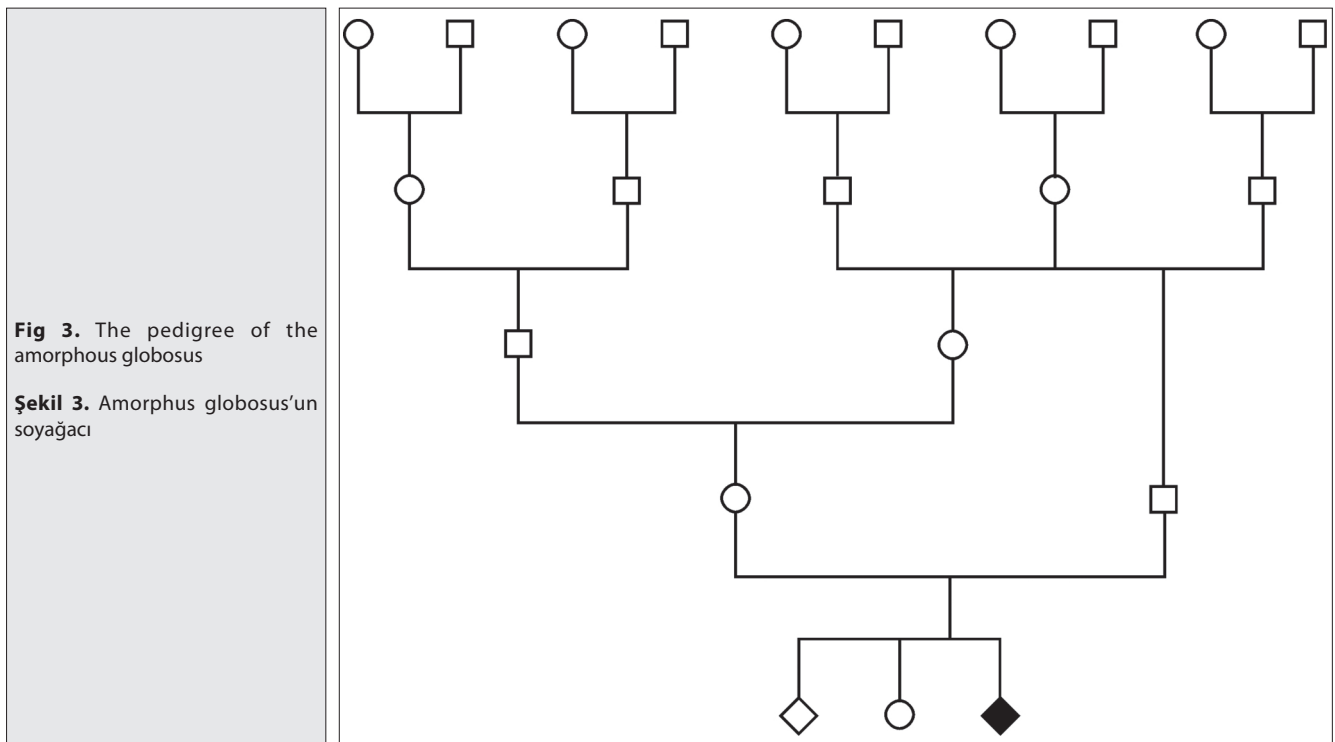
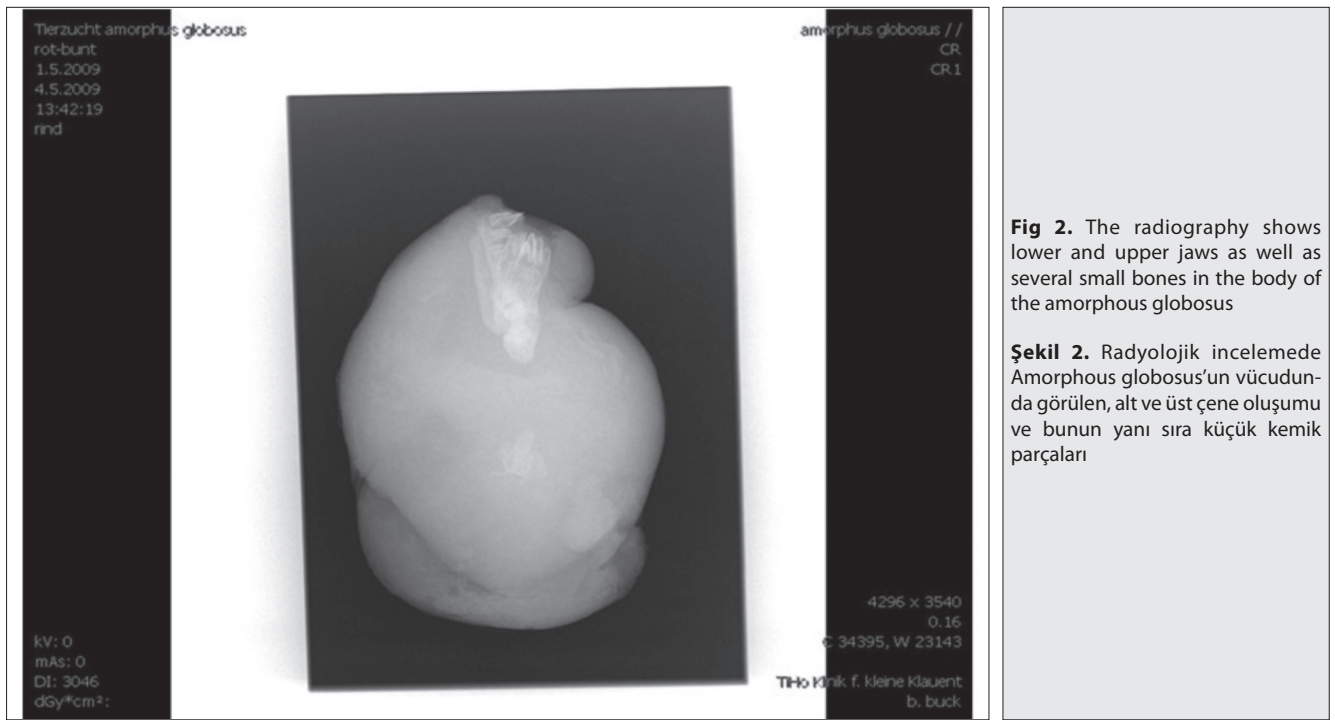

body with extremities. The acardius acormus consists of a partially developed head and brain. The acardius acephalus is lacking the head and thoracic organs [4,14].

Macroscopical findings in AG are usually a spherical or ovoid form of the body, covered with skin and hairs, and the umbilical cord [8,11,15]. Moreover, an imperfect tongue, oral or/and anal cavity, digestive organs or their vestiges were reported [11,13]. The present case had a small oral-like-

structure, in which a tongue-like structure with lips and three milk teeth were present.

Histopathological findings in AG showed different tissues with changeable degrees of development [7,8,11,13]. In agreement with previous reports we found connective tissue, skeletal muscles, lymph tissue, arterial vessels, cartilage tissue as well as tubular and glandular structures. Further, the present case had no adipose and necrotic tissues.

In agreement with previous reports showing various bone formations in the spherical body forms [10,12,16], we found lower and upper jaws with teeth and remnants of a bony tail with cartilage in the present case.

There are three different hypotheses on the etiopathogenesis of amorphous fetus. First, failure of heart formation probably due to insufficient splanchnic mesodermal elements, second anastomosis of the umbilical vessels causing a backward circulation in one of the twins and an obliteration of the heart anlage [7] and third interference with the return flow of blood from the placenta to the twin. The second hypothesis is generally believed as the cause of most amorphous anomalies. The inbreeding coefficient for the present case was 6.25% due to a common ancestor on the maternal and paternal side.

In conclusion, an anastomosis of artery to artery or vein to vein could not be found in the present amorphous case and thus, this hypothesis could be ruled out. Two large blood vessels and many small vessels were observed in the umbilical cord-like structure in the present case. However, only very few blood cells were noted in the lumen suggesting that the present case may have been caused by insufficient blood supply and in consequence to an obliteration of the heart anlage. Support was obtained for this assumption from previous reports with similar findings [8,10].

## REFERENCES

- Hosseini-Zadeh NG, Nejati-Javaremi A, Miraei-Ashtiani SR, Kohram H:** An observational analysis of twin births, calf stillbirth, calf sex ratio, and abortion in Iranian Holsteins. *J Dairy Sci*, 91, 4198-4205, 2008. DOI: 10.3168/jds.2008-1079
- Silva del Rio N, Stewart S, Rapnicki P, Chang YM, Fricke PM:** An observational analysis of twin births, calf sex ratio, and calf mortality in Holstein dairy cattle. *J Dairy Sci*, 90, 1255-1264, 2007. DOI: 10.3168/jds.S0022-0302(07)71614-4
- Citek J, Rehout V, Hajkova J:** Congenital disorders in the cattle population of the Czech Republic. *Czech J Anim Sci*, 54 (2): 55-64, 2009.
- Alderman B:** Foetus acardius amorphous. *Postgrad Med J*, 49, 102-105, 1973. DOI: 10.1136/pgmj.49.568.102
- Anwar T, Khan AI, Balasubramanian S, Jayaprakash R, Kannan TA, Manokaran S, Asokan SA, Veerepandian C:** A rare case of globosus amorphus in a goat. *Can Vet J*, 50, 854-856, 2009.
- Crossman PJ, Dicken PS:** Amorphus globosus in the mare. *Vet Rec*, 95, 22, 1974. DOI: 10.1136/vr.95.1.22-b
- Czarnecki CM:** Bovine holoacardius amorphus monster. *Can Vet J*, 17, 109-110, 1976.
- Hishinuma M, Takahashi Y, Kanagawa H:** Histological and cytological observation on a bovine acardius amorphus. *Jpn J Vet Sci*, 49, 195-197, 1987.
- Hishinuma M, Hoshi N, Takahashi Y, Kanagawa H:** Vasculature and chromosomal composition in bovine acardius amorphus. *Jpn J Vet Sci*, 50, 1139-1141, 1988.
- Kamimura S, Enomoto S, Goto K, Hamana K:** A globosus amorphus from an invitro fertilized embryo transferred to a Japanese black cow. *Theriogenol*, 40, 853-858, 1993. DOI: 10.1016/0093-691X(93)90220-Y
- Kojima Y, Kawata K:** Morphological observation on two cases of acardius amorphus in holstein-friesian cattle. *Jpn J Vet Res*, 8, 261-273, 1960. DOI: 10.14943/jjvr.8.1-4.261
- Neal FC, Wilcox CJ:** Double acardius amorphus case in brown Swiss cow. *J Dairy Sci*, 50, 236, 1967. DOI: 10.3168/jds.S0022-0302(67)87395-8
- Sugiyama M, Nomura K, Kajigaya H, Umeda M, Isoda M, Hatakeyama N:** Pathomorphological findings of acardius amorphus of cattle. *Bull Nippon Vet Zootech Coll*, 34, 47-54, 1985.
- Napolitani F, Schreiber I:** The acardiac monster. A review of the world literature and presentation of 2 cases. *Am J Obstet Gynecol*, 80, 582-589, 1960.
- Fischer UR, Hofmeister B:** Abnormal multiple pregnancy with septuplets in a cow. *Tierärztl Prax*, 4, 253-256, 2013.
- Pearson LK, Rodriguez JS, Tibary A:** Theriogenology question of the month. *JAVMA*, 238, 1261-1263, 2011. DOI: 10.2460/javma.238.10.1261